



Classic Forklift



SHOWN IN STANDARD YELLOW COLOR

25HP

| KUBOTA V1505 | 4-CYL | 1.5L | TIER 4 FINAL |

The best keeps getting better.

From the time beekeepers began using forklifts to handle and transport beehives and apiary equipment, the Hummerbee Classic rough terrain forklift has been the most preferred machine in the industry. Over the years, we have made vast improvements to enhance the power, efficiency, and reliability of the most popular apiary and orchard forklift in the world. With its highly capable engine, optimized hydraulics, and beefed-up center joints, today's Hummerbee Classic is built to outperform any forklift in its class. That's what you expect, and that's what we deliver.

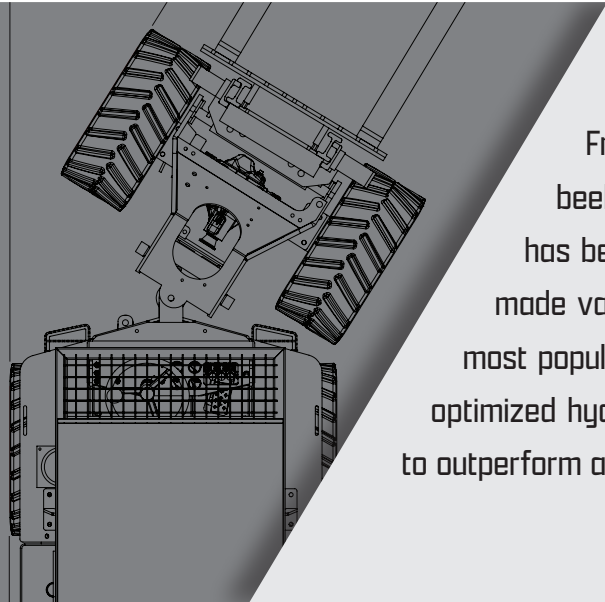

Hummerbee Classic

ROUGH TERRAIN FORKLIFT

TAILOR-MADE FOR THE WAY YOU WORK

Adaptability, Simplified

The Hummerbee Classic is the most adaptable and configurable rough terrain forklift ever designed and engineered for the apiary and orchard industries. Whether you're a veteran crop pollinator or a new kid on the block, we have a Classic forklift with your name on it.

The Classic can be equipped with multiple variations of controls, gauges, drives, hydraulics, lights, tools, and masts to meet your unique work requirements. Unlike some machines that need to be modified into a forklift, the Classic was born to be a forklift.

When it comes to simplicity, the Hummerbee Classic is legendary. The Classic is designed for easy operation and maintenance, increasing productivity and reducing down time. And being powered by a Kubota 24.8 HP diesel engine means there are no electronic Tier 4 emissions components to maintain.

Durability accompanies Power

The popular articulating and oscillating chassis design still remains true to its traditional roots, providing stable mobility on even the roughest terrain.

Equipped with our standard Eaton® single-speed hydrostatic transmission, the Classic effortlessly generates the power you want, at the speed you need. Upgraded auxiliary hydraulic components provide more reliable, responsive, and powerful tool operation than ever before.

Efficiency meets Value

With a 1,600 lb. lift capacity, and weighing in at only 4,860 lbs., the Classic is a real workhorse in a compact, lightweight package that's easy to maneuver and transport. And, the Clear-View mast allows for faster, safer loading and navigation.

Excellent fuel efficiency, paired with a large capacity fuel tank, keeps the Classic working uninterrupted all day long. Combine that with decades of proven performance and an attractive price, and the Hummerbee Classic offers exceptional value.

Peace of Mind

We're so confident in the quality and durability of the Hummerbee Classic, we back it up with a 2-Year, Parts & Labor Warranty.

Classic Specifications:

Engine:	Kubota V1505, 1.5L, 4-Cyl., Tier 4 Final
Horsepower:	25 hp @ 2,600 RPM
Torque:	68.5 Ft-Lbs @ 1,700 RPM
Transmission:	4WD: Single Speed; 2-Speed Optional
Maximum Speed:	8 MPH / 11 MPH-High; 5 MPH-Low
Fuel Capacity:	15 Gallons
Hydraulic Oil Capacity:	13 Gallons (Max)
Hydraulic Steering:	5 GPM
Aux. Hydraulics Flow:	13 GPM (Optional Configurations)
Operating Weight:	4,860 lbs. w/Liquid Filled Tires
Fork Length:	42" Standard; 48" Optional
Overall Length:	97" w/o Forks; 140.5" w/42" Forks
Overall Width:	55" w/Standard Tires
Overall Height:	89"; 99" w/Optional 144" Mast
Maximum Mast Height:	126" Standard; 144" Optional
Maximum Lift Capacity:	1,600 lbs.; 2,000 lbs. w/Counterweight
Pick & Carry Capacity:	3,000 lbs. w/Counterweight
Mast Side Shift:	6"
Mast Tilt:	16 Degrees
Turning Radius:	44" - Inside / 99" - Outside
Frame Oscillation:	Degrees
Standard Tires:	29x12.50x15; Liquid Filled; Ag
Wheel Base:	47.5"
Ground Clearance:	8" from Ground to Transfer Case
Standard Color:	Yellow

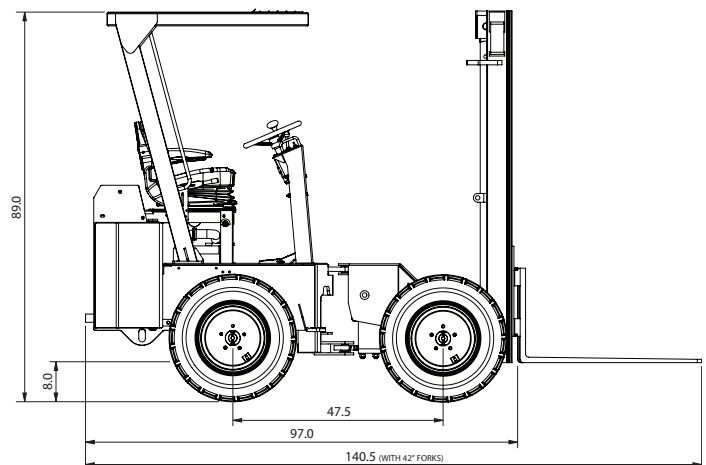

REV. 03-2026



(800) 943-8677

www.hummerbee.com | info@hummerbee.com

200 Quicksilver Lane | Edmore, MI | 48829

